

IFV *LINED BUTTERFLY VALVES*

italprotec
critical fluids solutions



Product Information





1. Product Characteristics

1.1. General Characteristics

Informazioni prodotto

1. Caratteristiche Prodotto

1.1. Caratteristiche Generali

ENG	IFV Butterfly Valve with TFM Liner	Valvola IFV rivestita in TFM	ITA
Body Types	WAFER (W) 	LUG (L) 	Tipologia Corpo
Scope of Application	Butterfly valve lined with TFM/PFA for high chemical demands. To shut off and control corrosive and abrasive liquids or gases. For specific application consider the correspondent directives	Valvola a farfalla rivestita in TFM/PFA per l'intercettazione e la regolazione di liquidi corrosivi o abrasivi e gas nell'industria chimica	Applicazione
Face to Face Dimensions	According to ISO 5752, Basic Range 20; DIN EN 558-1, Basic Range 20	In accordo alla norma ISO 5752, range base 20; DIN EN 558-1, range base 20	Scartamento
Head Flange	According to EN ISO 5211	In accordo alla norma EN ISO 5211	Flangia superiore
Max. Operating Pressure	10 bar (DN 40-600), 6 bar (DN 650-1050), Vacuum -0,1 bar	10 bar (DN 40-600), 6 bar (DN 650-1050) vuoto -0,1 bar	Pressione di esercizio Max.
Connection Standards	PN16 (DN 40-150), PN10 (DN 200-600), PN6 (DN 700-1050), ANSI cl.150	PN16 (DN 40-150), PN10 (DN 200-600), PN6 (DN 700-1050), ANSI cl.150	Connessione Standard
Temperature Range	-20°C up to +200°C (cp. Pressure-Temperature Diagram in this Publication)	Da -20°C a +200°C (consultare il diagramma pressione-temperatura nella pagina successiva)	Campo temperatura d'impiego
Identification Marking	EN 19	EN 19	Marcatura
In-Shop Testing	<ul style="list-style-type: none"> - Porosity Test of Disc Coating (PFA) and Liner (TFM) acc. to DIN EN 60243-1 - Leakage Test acc. to EN 12266-1/P12 Leakage Rate A - Check of Torque of each Valve acc. to internal Guidelines 	<ul style="list-style-type: none"> - Test di porosità del rivestimento del disco (PFA) e rivestimento corpo (TFM) in secondo DIN EN 60243-1 - Test di dispersione secondo EN 12266-1/P12 tasso di perdita A - Controllo del valore di coppia per ogni valvola 	Controlli interni
TA-Air	Compliance Leakage Certificate according to Position 5.2.6.4. of the Technical Instruction Air (TA-Air), VDI 2440	Certificato di conformità di dispersione in accordo alle posizioni 5.2.6.4 del Technical Instruction Air (TA-Air), VDI 2440	TA-Luft
	Compliance of the Safety Requirements of the Appendix I of the European Pressure Equipment Directive 97/23/EG for Fluids Group 1 and 2	Rispetto dei requisiti di sicurezza appendice I della direttiva Europea sui dispositivi a pressione 97/23/EG per i fluidi dei gruppi 1 e 2	
Atex	Atex compliant Version for explosive Surroundings Group II, Zones 0,1,2 (and 20, 21, 22 respectively)	Conformità Atex per ambienti esplosivi Gruppo II, zone 0, 1, 2 (e rispettivamente 20, 21, 22)	Atex

IFV BUTTERFLY VALVE

VALVOLA A FARFALLA IFV

1.2. Technical Characteristics

1.2. Caratteristiche tecniche

Pressure-Temperature-Diagram—Diagramma Pressione Temperatura

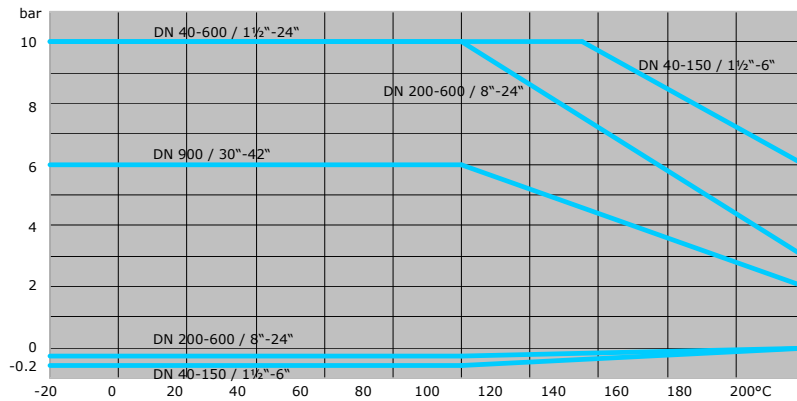

Flow Curve—Curva di flusso

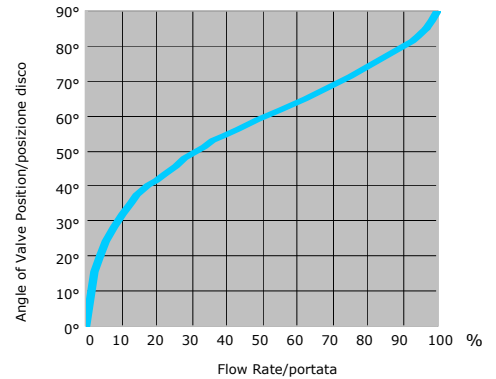

Liquids / Liquidi

$$Kv = Q \sqrt{\frac{SG}{\Delta p}}$$

Gases / Gas

$$Kv = \frac{Q_H}{514} \sqrt{\frac{SG_H \cdot T}{\Delta p \cdot p_2}}$$

Flow Rate Kv in m³/h 90° degree pos.

Portata Kv in m³/h con pos. valvola a 90°

Description	Symbol/simbolo	Unit/Unità	Descrizione
Coefficient of Flow Rate	Kv	m³/h	Coefficiente di portata
Volume Flow	Q	m³/h	Volume portata
Volume Flow	Q _N	Nm³/h	Volume portata
Density	SG	kg/dm³	Densità
Density	SG _N	kg/Nm³	Densità
Operating Pressure	P ₂	bar	Pressione di esercizio
Pressure Drop	Δp	bar	Perdita di carico
Operating Temperature	T	°K	Temperatura di esercizio

Pollici	Kv	DN
1 1/2"	136	40
2"	193	50
2 1/2"	266	65
3"	392	80
4"	585	100
5"	1'015	125
6"	1'495	150
8"	3'050	200
10"	4'510	250
12"	6'500	300
14"	8'760	350
16"	11'350	400
18"	14'400	450
20"	18'000	500
24"	29'200	600
30"	54'400	
36"	81'016	900
42"	109'100	

1.3. Advantages of the TFM Liner

TFM is manufactured with PTFE and a 1% fraction of perfluoropropyl vinyl ether (PPVE). While the properties of conventional PTFE (excellent all-around chemical resistance, application in a wide service temperature range and extreme resistance to embrittlement or aging) will be conserved, the additive PPVE leads to a better allocation of the PTFE particles and thus to a higher density of the molecular structure. The following extra advantages are resulting:

	Advantages of TFM compared to ordinary PTFE	Vantaggi del TFM rispetto al PTFE	
A.	Cold flow, measured as deformation under load, is significantly lower for TFM than for conventional PTFE: It is about the same value as conventional PTFE with 25% glass fibre.	Il trafilamento a freddo, misurato come deformazione sotto carico, è significativamente più basso per il TFM che per il PTFE; equivale approssimativamente allo stesso valore del PTFE caricato vetro al 25%.	A.
B.	Reduced permeation leads to better barrier properties.	Ridotto grado di permeazione che migliora le proprietà di tenuta.	B.
C.	The smooth surface provokes only a slight abrasion of the liner and less particles in the medium.	La superficie liscia più compatta permette solo una leggera abrasione del rivestimento con minimo rilascio di particelle nei fluidi.	C.

1.3. Vantaggi del rivestimento in TFM

Il TFM è prodotto con PTFE ed aggiunta dell'1% di perfluoro-propil-vinil-etero (PPVE). Mentre le proprietà del PTFE convenzionale vengono mantenute (eccellente resistenza chimica, applicazione in una vasta gamma di temperature di esercizio ed estrema resistenza all'infrangimento o all'invecchiamento), l'additivo PPVE porta ad una migliore distribuzione delle particelle di PTFE e quindi ad una maggiore densità della struttura molecolare. Ciò comporta i seguenti vantaggi:

A. Permanent Deformation after Cyclic Load Deformazione permanente dopo carico ciclico

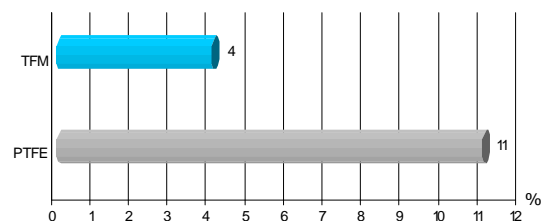

Load: 150 bar during 100 hours, Temperature 23°C
Permanent Deformation in %, 24 hrs after Load Removal

Carico: 150 bar, durata 100 ore, temperatura 23 °C
Deformazione permanente in %, 24 ore dopo avere tolto il carico.

IFV BUTTERFLY VALVE

VALVOLA A FARFALLA IFV

B. Permeability of Selected Chemicals Permeabilità di alcuni prodotti chimici

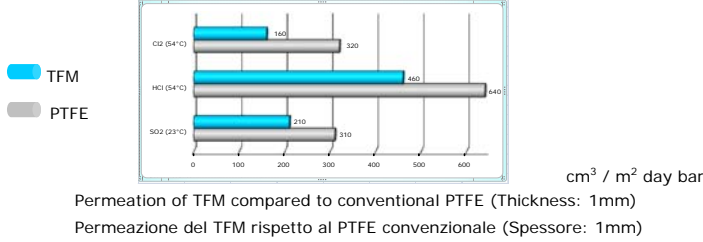

C. Surface Property at 50x Magnification Proprietà superficie con ingrandimento 50x

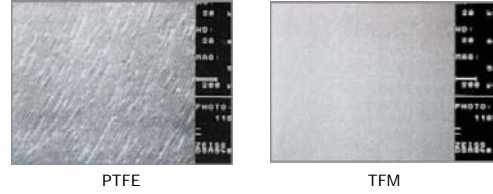

The advantages of TFM has a positive effect on the reliability of the installation and durability of the valve. Furthermore, downtimes and maintenance are minimised while the operating safety is increased.

Le caratteristiche del TFM hanno un effetto positivo sull'affidabilità degli impianti e sulla durata delle valvole. Ferme e manutenzioni sono ridotte al minimo, mantenendo anche una maggiore sicurezza di esercizio.

2. Construction

2. Costruzione

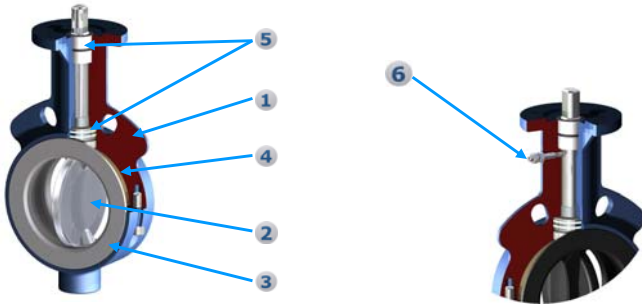

Pos	Description	Descrizione	Pos
1	Split Body	Corpo in due parti	1
2	Disc	Disco	2
3	Liner	Rivestimento	3
4	Back-Up	Sottostrato	4
5	Bearing and Pressure Packages	Tenute pacco a molla	5
6	Atex Type*	Tipo Atex*	6

3. Dimensions

3. Dimensioni

Wafer (W)

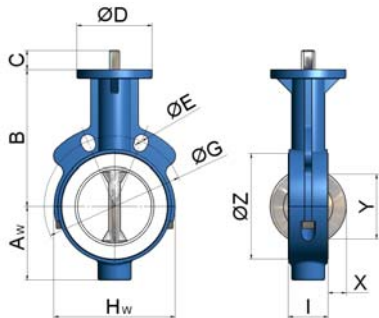

Lug (L)

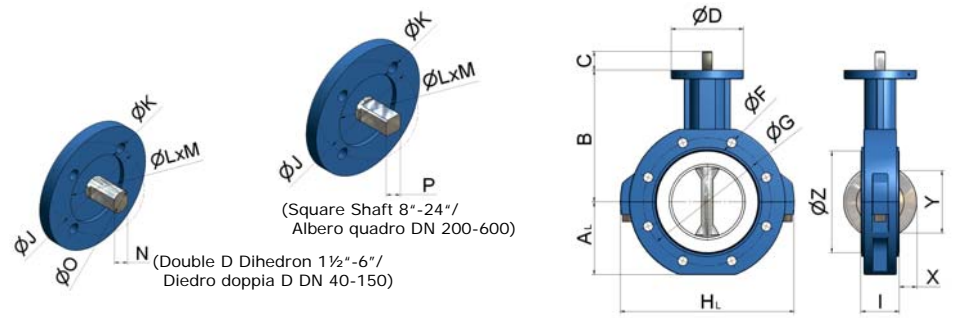

Inch ANSI	A _w	A _L	B	C	øD	øE DIN	øF DIN	øG DIN	øE ANSI	øF ANSI - (UNC)	øG ANSI	H _w	H _L	I	øJ	øK	øLxM	N	øO	P	X	Y	Z	ISO	kg _w	kg _L	DN DIN
1 1/2"	70*	70	95	19	65	4x18	4xM16	110	2x16	4x1/2"-13	98.4	142*	142	33	50	4x7	36x3.5	9	13		7	34	76	F05	1.5	2.5	40
2"	56	58	130	19	102	2x18	4xM16	125	2x18	4x5/8"-11	120.6	104	153	43	70	4x9	56x3.5	11	14		6	31	85	F07	3.0	5.0	50
2 1/2"	67	65	146	19	102	2x18	4xM16	145	2x18	4x5/8"-11	139.7	128	173	46	70	4x9	56x3.5	11	14		11	48	106	F07	4.0	7.0	65
3"	84	88	165	19	102	2x18	8xM16	160	2x18	4x5/8"-11	152.4	144	210	46	70	4x9	56x3.5	11	14		17	63	122	F07	5.0	8.1	80
4"	100	102	185	25	102	2x18	8xM16	180	2x18	8x5/8"-11	190.5	164	245	52	70	4x9	56x3.5	14	18		27	90	143	F07	6.3	10.8	100
5"	110	116	202	25	102	2x18	8xM16	210	2x21	8X3/4"-10	215.9	194	272	56	70	4x9	56x3.5	14	18		38	118	166	F07	7.7	14.5	125
6"	125	127	217	30	102	2x22	8xM20	240	2x21	8X3/4"-10	241.3	220	295	56	70	4x9	56x3.5	17	22		47	137	193	F07	10.0	15.8	150
8"	158	160	245	26	152	2x22	8xM20	295	2x21	8X3/4"-10	298.4	274	364	60	102	4x11	71x3.5		24	19	71	189	251	F10	16.5	24.6	200
10"	190	193	270	30	152	2x22	12xM20	350	2x25	12x7/8"-9	361.9	330	431	68	102	4x11	71x3.5		28	22	92	239	301	F10	24.5	33.3	250
12"	225	227	308	30	152	2x22	12xM20	400	2x25	12x7/8"-9	431.8	380	511	78	102	4x11	71x3.5		28	22	112	290	349	F10	37.0	57	300
14"	256*	256	330	37	152	16x22	16xM20	460	12x29	12x1"-8	476.2	571*	571	92	125	4x13	87x3.5		35	27	125	328	414	F12	87*	87	350
16"	292*	292	365	37	152	16x26	16xM24	515	16x29	16x1"-8	539.7	643*	643	102	125	4x13	87x3.5		35	27	146	377	460	F12	107*	107	400
18"	311*	311	400	50	175	20x26	20xM24	565	16x32	16x1 1/8"-7	577.8	684*	684	114	140	4x17	102x4.5		47	36	164	417	515	F14	152*	152	450
20"	340*	340	435	50	175	20x26	20xM24	620	20x32	20x1 1/8"-7	635.0	745*	745	127	140	4x17	102x4.5		47	36	184	477	570	F14	185*	185	500
24"	398*	398	510	64	210	20x30	20xM27	725	20x35	20x1 1/4"-7	749.3	863*	863	154	165	4x21	131x5.5		58	46	215	560	672	F16	254*	254	600
30"	482*	482	608	90	210				28x35	28x1 1/4"-7	914.4	1040*	1040	154	165	4x21	131x5.5	**	70	**	289	716	851	F16	300*	300	
36"	573*	573	684	90	300	28x33	28xM30	1050	32x42	32x1 1/2"-6	1085.8	1232*	1232	154	254	8x17	202x5.5	**	70	**	360	860	1016	F25	460*	460	900
42"	660*	660	768	90	300				36x42	36x1 1/2"-6	1257.3	1402*	1402	154	254	8x17	202x5.5	**	80	**	434	1009	1170	F25	500*	500	

* = Body Type: Lug (L), Screw-in tap hole drilled through
** = Special Design

* = Tipo corpo: Lug (L), Filettatura interna fori passanti
** = Disegno speciale

IFV BUTTERFLY VALVE

VALVOLA A FARFALLA IFV

4. Add-ons

4.1. Hand Lever and Gearbox

Pollici	C _n	W	kg	DN
1½" - 3"	46	230	0.3	40 - 80
4" - 6"	51	270	1.4	100 - 150
8" - 12"	56	325	2.4	200 - 300

Pollici	C _g	Q	R	S	T	U	V	kg	DN
2" - 3"	64	138	125	84	67.5	43.5	45.7	2.0	50 - 80
4" - 5"	64	144	160	84	67.5	43.5	45.7	2.0	100 - 125
6"	75	201	160	112	81.5	52.5	55	3.9	150
8"	75	203	200	112	81.5	52.5	55	3.9	200
10"	75	203	200	112	81.5	52.5	55	3.9	250
12"	91	261	250	135	115	68.8	72.5	7.7	300
14" - 16"	91	266	315	135	115	68.8	72.5	7.7	350 - 400
18" - 20"	87	204	315	138	105	71	83	9.0	450 - 500
24"	90	227	315	200	126	86	101	14.5	600

Form	Part	Material	Materiale	Componente	Particolare
Hand Lever	Handhold	St. Steel	Acciaio inox	Impugnatura	Leva
	Notched Plate	St. Steel	Acciaio inox	Piastra posizioni	
Gearbox	Gearbox Casing	GG 25 / Epoxy	GG 25 / Epoxy	Corpo riduttore	Riduttore
	Shaft	St. Steel	Acciaio inox	Albero	
	Handwheel	Steel / Epoxy	CS / Epoxy	Volantino manuale	

4. Materiali aggiuntivi

4.1. Leva manuale e riduttore

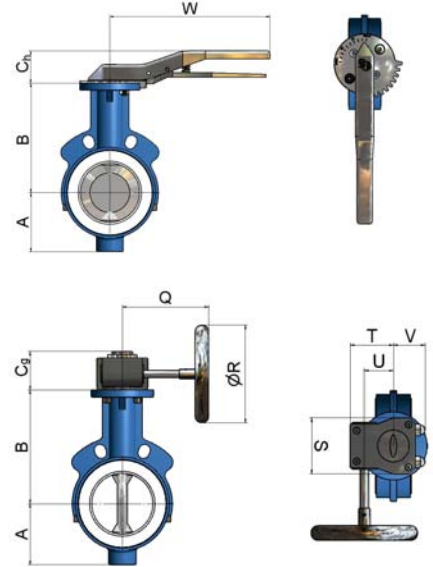

4.2. Torque for Drives

DN	40	50	65	80	100	125	150	200	250	300	350	400	450	500	600	900	DN		
Inches	1½"	2"	2½"	3"	4"	5"	6"	8"	10"	12"	14"	16"	18"	20"	24"	30"	36"	42"	pollici
Initial Breakaway Torque (NM)	15	30	35	45	60	80	110	190	300	400	450	500	600	650	750	2000	2700	3600	Momento torcente (NM)
Max. allowable Torques Shaft 1.4581/1.4435/1.4301	25	61	61	61	179	179	309	309	604	604	1200	1600	1950	2400	3200	8000	12000	12000	Coppia massima applicabile 1.4581/1.4435/1.4301

The indicated initial breakaway torques includes 10% security.

I valori del momento torcente iniziale includono il 10% di sicurezza.

4.2. Coppia per riduttori

5. Coding

The **Italprotec** Butterfly Valve **IFV** is based on the scheme of concentric and soft sealing valves. The construction enables any possible combination of disc, liner and body. Disc and shaft are one-piece. Different models and qualities of body and liner are available.

Le Valvole a farfalla **Italprotec IFV** sono costruite sul principio del posizionamento concentrico del disco che permette una chiusura morbida e tenuta garantita. La costruzione consente ogni possibile combinazione di tipo di disco, rivestimento e corpo. Disco ed albero sono realizzati in unico pezzo e le valvole sono disponibili in diverse dimensioni, tipologie e rivestimenti.

5. Codifica

Disc/Disco	Liner/Rivestimento	Back-Up/Sottostrato	Body/Corpo	Body Type/Tipo corpo	Standard	Flange
P - PFA	T - TFM (PTFE)	S - Silicone	A - Aluminium/Epoxy	W - Wafer	A - ANSI	1 - PN 10
C - PFA cond.	C - TFM cond.	V - Viton	G - 0.7073(GGG40.3)/Epoxy	E - Lug	D - DIN	2 - PN 16
S - St. Steel/acciaio inox	F - TFM con. FDA	E - EPDM	S - St. Steel/SS			1 - 150 lbs
F - Polished St. Steel/SS elettrolucidato	U - UHMPE		C - C-Steel/CS			
T - Titanium/Titanio Grade/Grado 2						
H - Hastelloy C22						
E - Halar E-CTFE						

Italprotec Butterfly Valve IFV DN100/ Valvola a farfalla Italprotec IFV DN100

Type/Tipo	Disc/Disco	Liner/Rivestimento	Back-Up/Sottostrato	Body/Corpo	Body type / tipo corpo	Standard and Flange/Standard e flange	DN
IFV-	P	T	S	G	W	D1 -	100
	PFA	TFM	Silicone/Silicone	0.7073(GGG40.3)Epoxy	wafer	DIN PN 10	100

ITALPROTEC SAS

VIA 1° MAGGIO, 11 • 20040 CAVENAGO BRIANZA (MILANO) • ITALY • TEL. +39 02 953 395 00 • FAX +39 02 953 350 75
<http://www.italprotec.com> • e-mail: info@italprotec.com

